

# 16. REAR WHEEL/SUSPENSION

---

COMPONENT LOCATION .....	16-2	REAR WHEEL .....	16-6
SERVICE INFORMATION .....	16-3	SHOCK ABSORBER .....	16-15
TROUBLESHOOTING .....	16-5	SWINGARM .....	16-17

# REAR WHEEL/SUSPENSION

## COMPONENT LOCATION

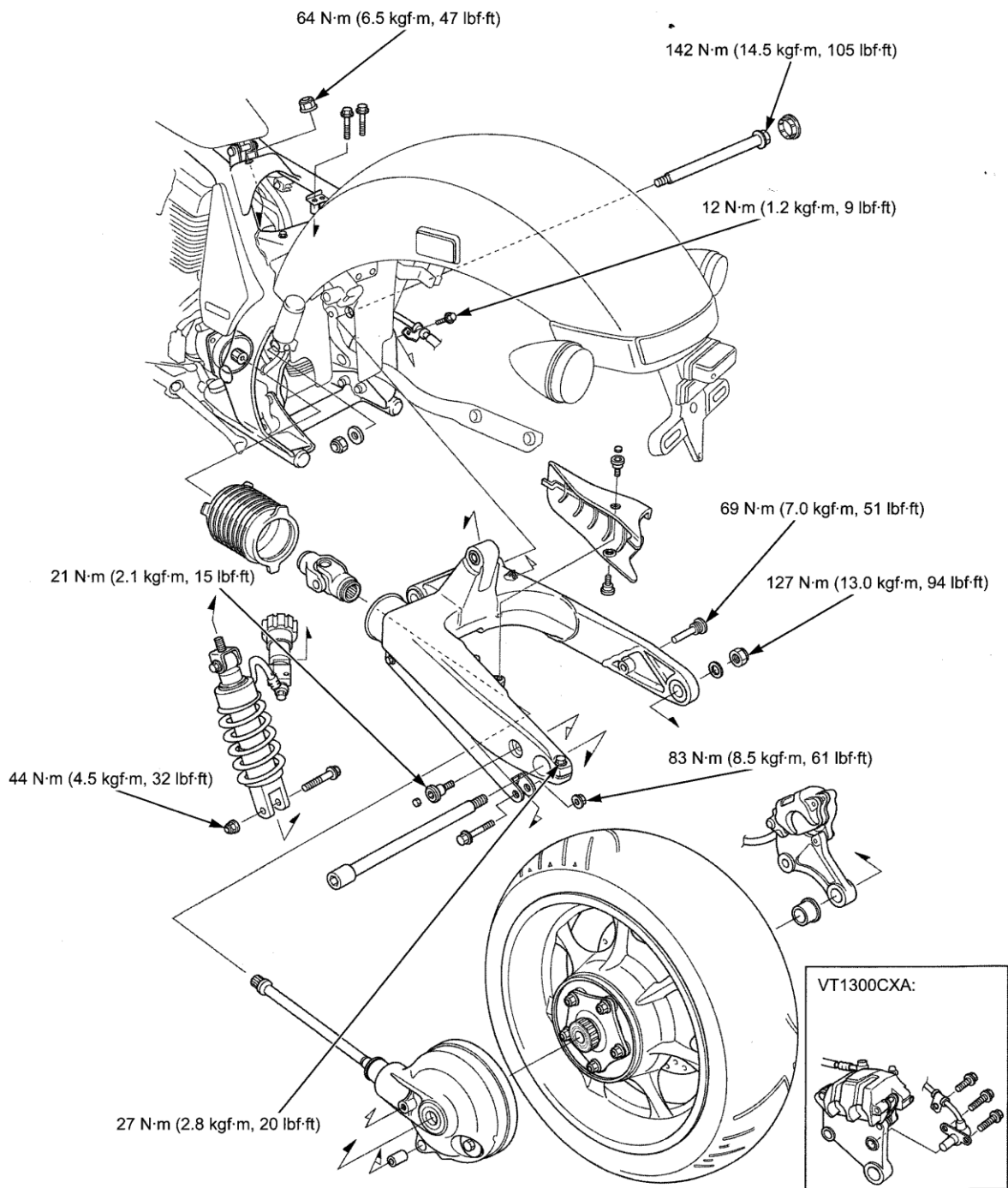

**SERVICE INFORMATION**

**GENERAL**

- When servicing the rear wheel, shock absorber or swingarm, support the motorcycle using a safety stand or hoist and rear wheel off the ground.
- A contaminated brake disc or pad reduces stopping power. Discard contaminated pads and clean a contaminated disc with a high quality brake degreasing agent.
- Use only Honda Genuine replacement bolts and nuts for all suspension pivot and mounting points.
- Use only tires marked "TUBELESS" and tubeless valve stem on rim marked "TUBELESS TIRE APPLICATION".
- After the rear wheel installation, check the brake operation by applying the brake pedal.
- For hydraulic brake system service (page 17-4).

**SPECIFICATIONS**



Unit: mm (in)

ITEM		STANDARD	SERVICE LIMIT
Minimum tire tread depth		—	2.0 (0.08)
Cold tire pressure	Up to 90 kg (200 lbs) load	280 kPa (2.80 kgf/cm <sup>2</sup> , 41 psi)	—
	Up to maximum weight capacity	280 kPa (2.80 kgf/cm <sup>2</sup> , 41 psi)	—
Axle runout		—	0.2 (0.01)
Wheel rim runout	Radial	—	2.0 (0.08)
	Axial	—	2.0 (0.08)
Wheel balance weight		—	60 g (2.1 oz) max.
Shock absorber	Spring pre-load adjuster standard position	6 clicks out from full soft	—
	Rebound damping adjuster standard position	3/4 turns out from full hard	—





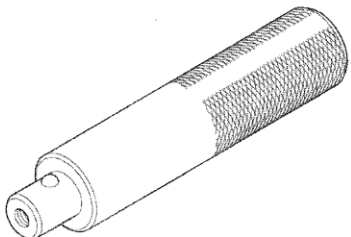
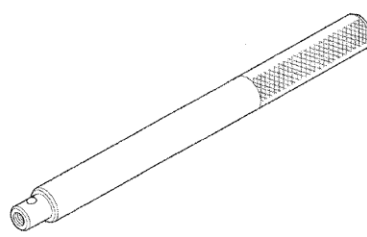

**TORQUE VALUES**

Rear brake disc socket bolt	42 N·m (4.3 kgf·m, 31 lbf·ft)	ALOC bolt; replace with a new one.
Driven flange nut	88 N·m (9.0 kgf·m, 65 lbf·ft)	U-nut
Rear axle nut	127 N·m (13.0 kgf·m, 94 lbf·ft)	U-nut
Rear axle pinch bolt	27 N·m (2.8 kgf·m, 20 lbf·ft)	
Shock absorber mounting nut	44 N·m (4.5 kgf·m, 32 lbf·ft)	U-nut
Shock absorber upper holder nut	64 N·m (6.5 kgf·m, 47 lbf·ft)	U-nut
Swingarm pivot bolt	142 N·m (14.5 kgf·m, 105 lbf·ft)	
Rear brake caliper stopper pin bolt	69 N·m (7.0 kgf·m, 51 lbf·ft)	ALOC bolt; replace with a new one.
Torque arm nut	83 N·m (8.5 kgf·m, 61 lbf·ft)	U-nut
Rear brake hose clamp bolt	12 N·m (1.2 kgf·m, 9 lbf·ft)	
Final gear case assembly layout bolt	21 N·m (2.1 kgf·m, 15 lbf·ft)	
Rear pulser ring mounting bolt (VT1300CXA)	7 N·m (0.7 kgf·m, 5.2 lbf·ft)	ALOC bolt; replace with a new one.

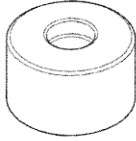
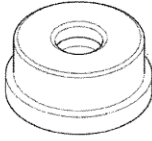
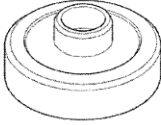
**TOOLS**

<p>Driver 07749-0010000</p> 	<p>Driver 07949-3710001</p> 	<p>Attachment, 24 x 26 mm 07746-0010700</p> 
---	---	---

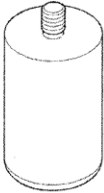
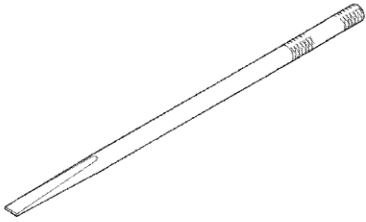
## REAR WHEEL/SUSPENSION

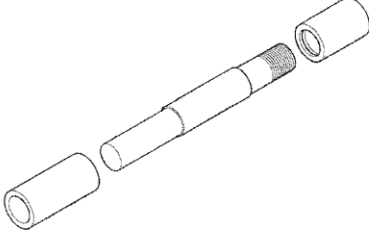
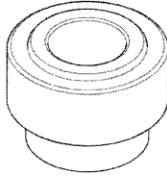
<p>Attachment, 28 x 30 mm 07946-1870100</p> 	<p>Attachment, 37 mm 07ZMD-MBW0200</p>  <p>or 07ZMD-MBWA200 (U.S.A. only)</p>	<p>Attachment, 42 x 47 mm 07746-0010300</p> 
<p>Attachment, 52 mm 07946-3710200</p> 	<p>Pilot, 20 mm 07746-0040500</p> 	<p>Pilot, 25 mm 07746-0040600</p> 
<p>Pilot, 28 mm 07746-0041100</p> 	<p>Pilot, 32 mm 07MAD-PR90200</p> 	<p>Bearing remover shaft 07GGD-0010100</p> 
<p>Bearing remover head, 25 mm 07746-0050800</p> 	<p>Installer, 15/23 07GMD-KT80100 ("Collar, 23 x 17 mm" is only required)</p>  <p>or 07GMD-KT8A110 (U.S.A. only)</p>	<p>Attachment, 30 mm I.D. 07746-0030300</p> 

Driver, 40 mm I.D.  
07746-0030100

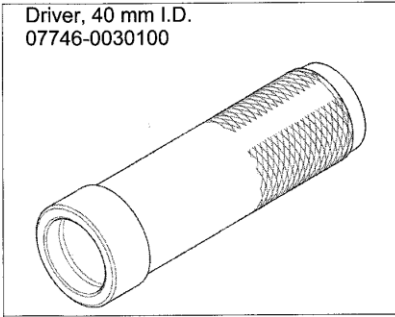

## TROUBLESHOOTING

### Soft suspension

- Improper shock absorber spring preload
- Incorrect suspension adjustment
- Weak shock absorber spring
- Oil leakage from damper unit
- Insufficient tire pressure
- Faulty tire

### Stiff suspension

- Incorrect suspension adjustment
- Bent damper rod
- Damaged shock absorber upper mount bushing
- Damaged shock absorber lower mount bearing
- Damaged swingarm pivot bearing
- Improperly tightened swingarm pivot
- Bent swingarm pivot
- Tire pressure too high

### Rear suspension noise

- Loose suspension fasteners
- Binding shock absorber case
- Worn shock absorber upper mount bushing
- Worn shock absorber lower mount bearing
- Worn or scored splines
- Faulty rear shock absorber
- Worn or damaged drive shaft or universal joint
- Worn or damaged pinion and ring gears
- Excessive backlash between pinion and ring gears
- Oil level too low

### Rear wheel wobbles

- Bent rim
- Unbalanced rear tire and wheel
- Insufficient tire pressure
- Faulty swingarm pivot bearings
- Axle fastener not tightened properly
- Faulty tire
- Worn or damaged final gear case bearing
- Worn or damaged wheel bearing
- Worn or damaged driven flange bearing
- Bent frame or swingarm

### Wheel turns hard

- Faulty wheel bearing
- Bent axle
- Brake drag (page 17-6)
- Worn or damaged final gear case bearing
- Worn or damaged wheel bearing
- Worn or damaged driven flange bearing

### Steering to one side does not track straight

- Bent frame
- Bent axle
- Worn swingarm pivot components

## REAR WHEEL/SUSPENSION

### REAR WHEEL

#### REMOVAL

VT1300CXA: Remove the bolts and rear wheel speed sensor.  
Remove the bolts and wire clamps.

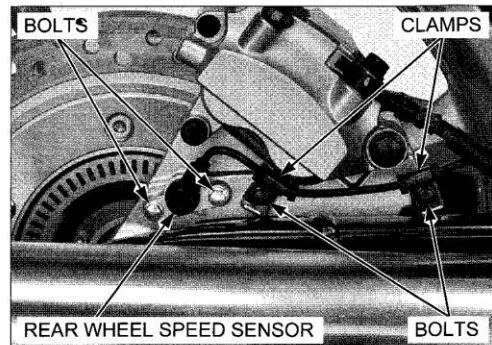

Remove the exhaust system (page 3-10).

*Do not reuse the pin bolt.* Loosen the axle nut and rear brake caliper stopper pin bolt.

Support the motorcycle using a safety stand or hoist and raise the rear wheel off the ground.

Remove the axle nut, washer and rear brake caliper stopper pin bolt.

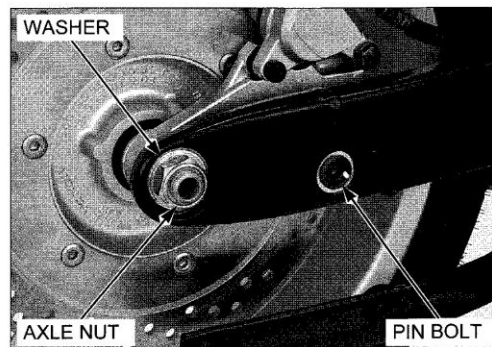

Loosen the axle pinch bolt and pull out the axle on the way.

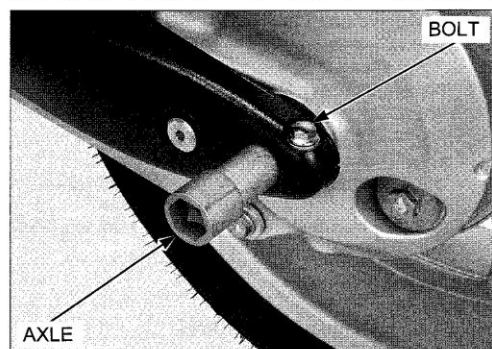

Remove the brake caliper/bracket and axle.

#### NOTE:

- Support the brake caliper so it does not hang from the brake hose. Do not twist the brake hose.
- Do not operate the brake pedal after removing the brake caliper. To do so will cause difficulty in fitting the brake disc between the brake pads.

Move the rear wheel to the right to separate it from the final drive gear case and carefully remove the rear wheel out of the swingarm.

#### NOTE:

- During rear wheel removal, hold the wheel securely and be careful not to damage the brake disc, gear case and swingarm.

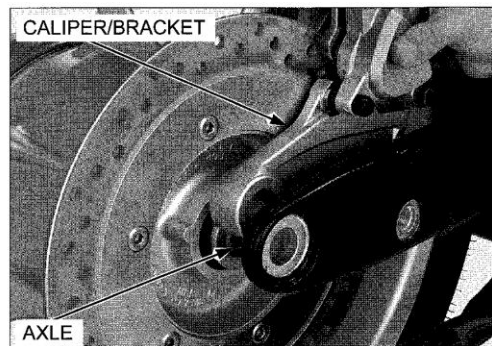

Remove the collar.

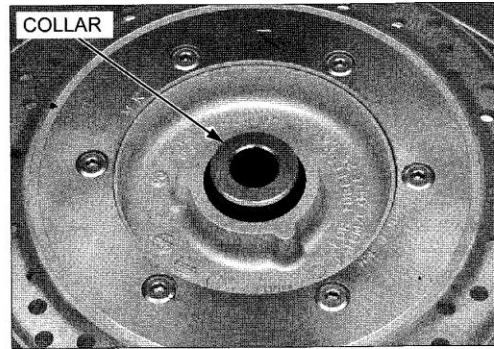

**INSPECTION**

**AXLE**

Set the rear axle on V-blocks.

Turn the axle and measure the runout using a dial indicator.

Actual runout is 1/2 the total indicator reading.

**SERVICE LIMIT: 0.2 mm (0.01 in)**

**WHEEL BALANCE**

For wheel balance servicing (page 15-14).

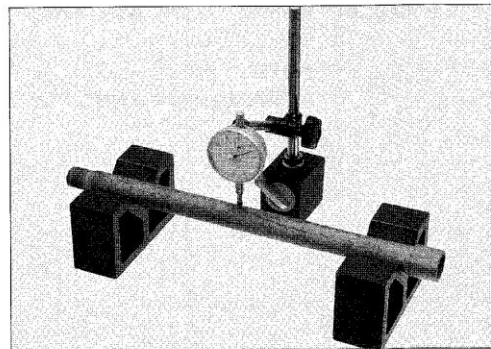

**WHEEL RIM**

Check the rim runout by placing the wheel in a truing stand.

Spin the wheel slowly and read the runout using a dial indicator.

Actual runout is 1/2 the total indicator reading.

**SERVICE LIMITS: Radial: 2.0 mm (0.08 in)**  
**Axial: 2.0 mm (0.08 in)**

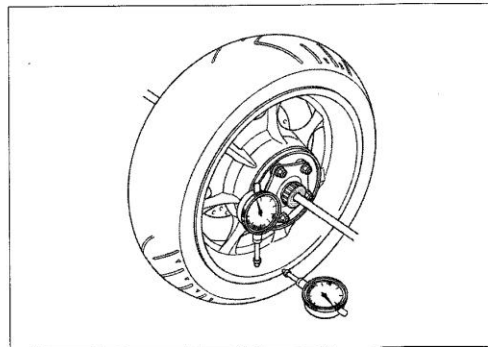

**WHEEL BEARING**

Remove the driven flange A/B (page 16-8).

Turn the inner race of each bearing with your finger. The bearings should turn smoothly and quietly. Also check that the outer race fits tightly in the hub.

Remove and discard the bearings if the races do not turn smoothly and quietly, or if the outer race fits loosely in the hub.

*Replace the wheel bearing in pairs.* Replace the wheel bearings, if necessary (page 16-8).

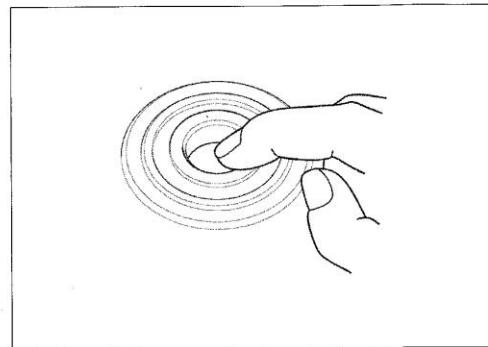

## REAR WHEEL/SUSPENSION

### FINAL DRIVEN FLANGE

Check the driven flange splines for wear or damage. If damaged, check the splines of the final drive gear case also.

Turn the inner race of each bearing with your finger. The bearings should turn smoothly and quietly. Also check that the outer race fits tightly in the driven flange A.

*Replace the drive flange bearing in pairs.*

Replace the driven flange bearings if necessary (page 16-8).

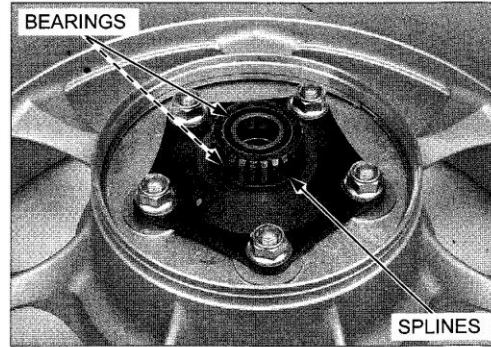

### DISASSEMBLY

VT1300CXA: Remove the torx bolts, pulser ring cover and pulser ring.

#### NOTE:

- Do not reuse the torx bolts.

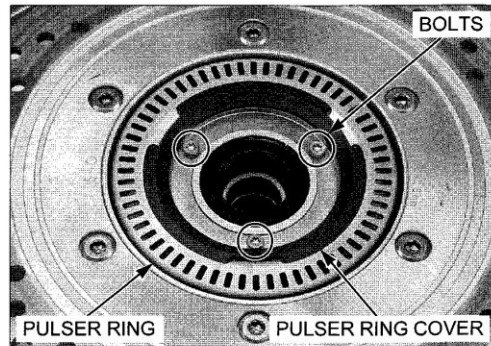

*Do not reuse the bolts.*

Loosen the brake disc socket bolts in a crisscross pattern in several steps and remove them.

Remove the brake disc and dust seal.

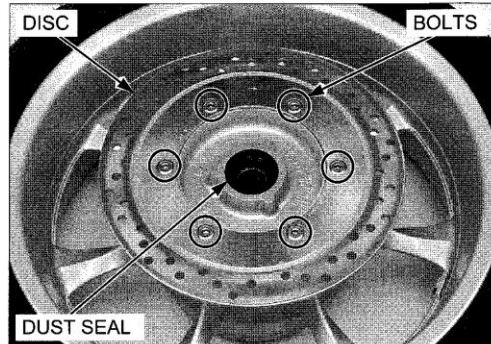

*If you will replace the driven flange A, loosen the flange nuts.*

Remove the O-ring, stopper ring and driven flange A/B.

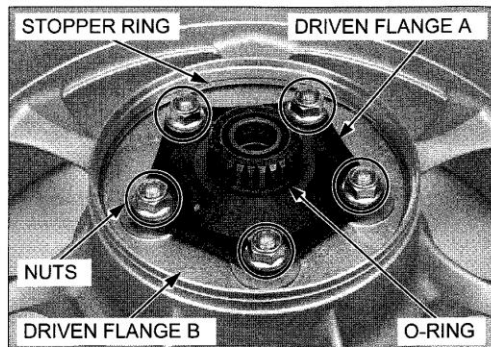



## REAR WHEEL/SUSPENSION

Remove the driven flange nuts and driven flange A from the driven flange B.

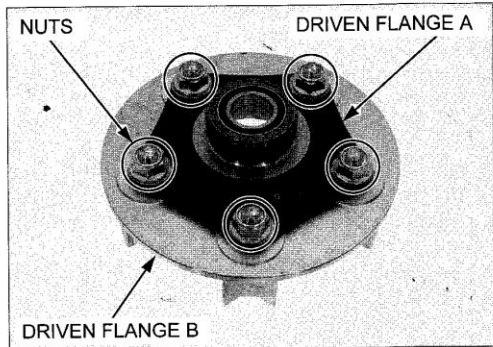

Remove the rubber dampers and O-ring.

Replace the rubber dampers as a set. Check the rubber dampers for deterioration or damage.

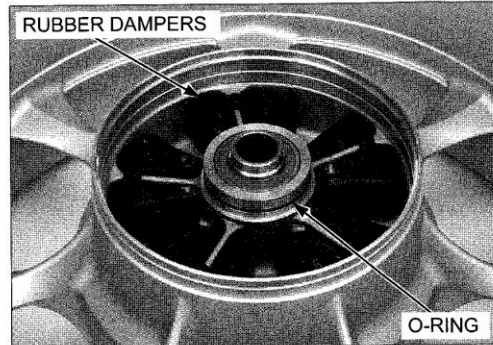

Install the remover head into the right side bearing.

From the opposite side of the wheel, install the remover shaft and drive the right side bearing out of the wheel hub.

Remove the distance collar.

**TOOLS:**

Bearing remover shaft 07GGD-0010100  
Bearing remover head, 25 mm 07746-0050800

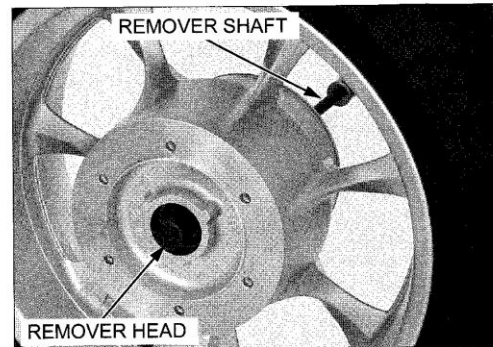

Remove the distance collar A and left side bearings.

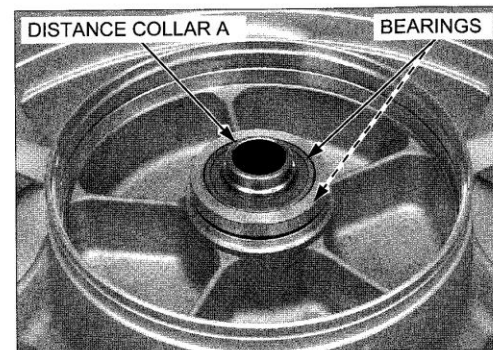

## REAR WHEEL/SUSPENSION

Drive out the driven flange bearings using the special tools.

**TOOLS:**

**Driver**  
**Attachment, 37 mm**

07749-0010000  
07ZMD-MBW0200  
or  
07ZMD-MBWA200  
(U.S.A. only)  
07746-0040600

**Pilot, 25 mm**

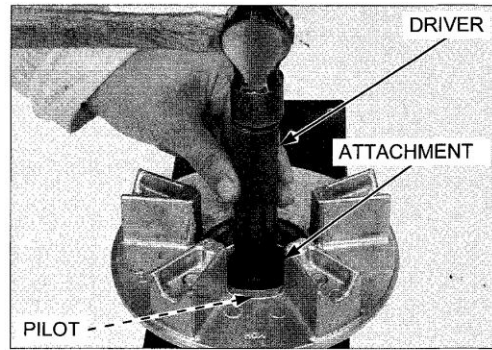

### ASSEMBLY

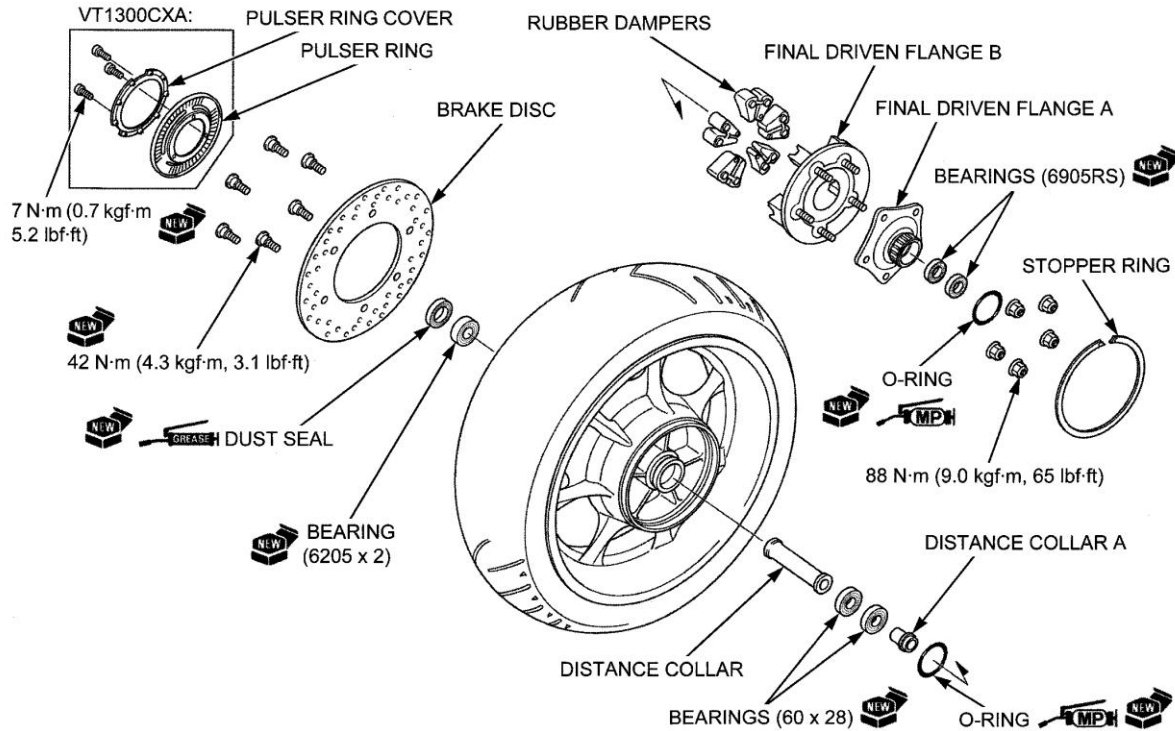

Drive in a new driven flange bearings until they are fully seated, using the special tools.

**NOTE:**

- Inside bearing: sealed side facing down
- Outside bearing: sealed side facing up

**TOOLS:**

**Driver**  
**Attachment, 42 x 47 mm**  
**Pilot, 25 mm**

07749-0010000  
07746-0010300  
07746-0040600

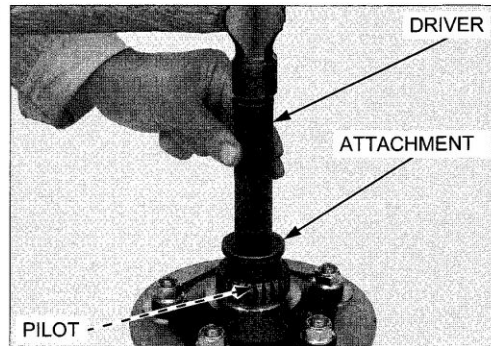

## REAR WHEEL/SUSPENSION

Drive in a new right side bearing until it is fully seated, using the special tools.

**TOOLS:**

**Driver** 07749-0010000  
**Attachment, 52 mm** 07946-3710200  
**Pilot, 25 mm** 07746-0040600

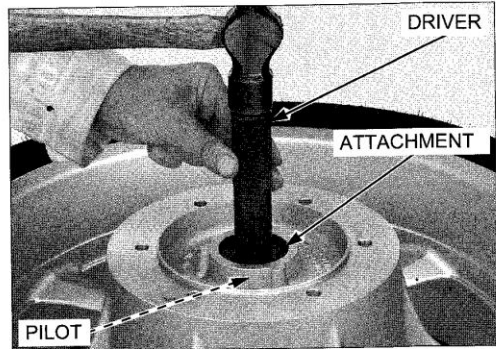

Drive in the distance collar A to new bearings.

**TOOLS:**

**Driver** 07749-0010000  
**Attachment, 28 x 30 mm** 07946-1870100  
**Pilot, 25 mm** 07746-0040600

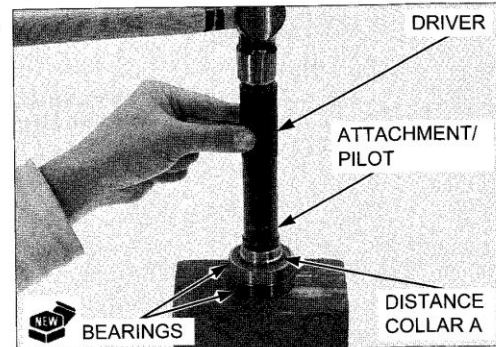

Install the distance collar.

Drive in the bearings/distance collar A using the special tool.

**TOOL:**  
**Driver, 40 mm I.D.** 07746-0030100

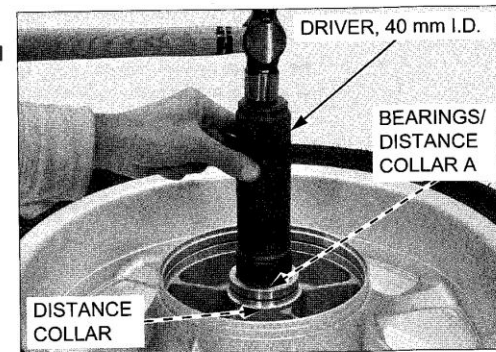

Install the rubber dampers as shown.

Apply molybdenum disulfide paste to the O-ring groove of the hub.

Install a new O-ring.



## REAR WHEEL/SUSPENSION

If the driven flange stud bolts are loose, tighten them.  
Be sure to verify the distance from the top of the stud to the driven flange as shown.

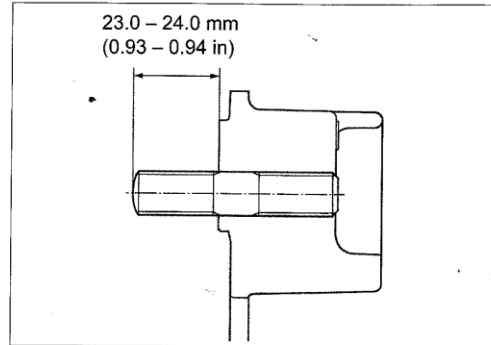

Install the driven flange A and driven flange nuts to the driven flange B.

**NOTE:**

- Tighten the driven flange nuts to the specified torque after installing the driven flange A/B.

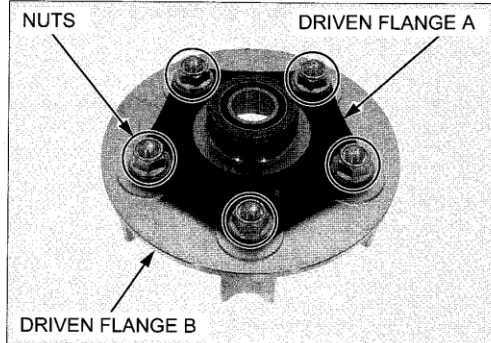

Apply 3 g (0.11 oz) minimum of molybdenum disulfide paste to the wheel hub and O-ring.

Install the driven flange A/B, by aligning the driven flange bosses with the rubber damper grooves.

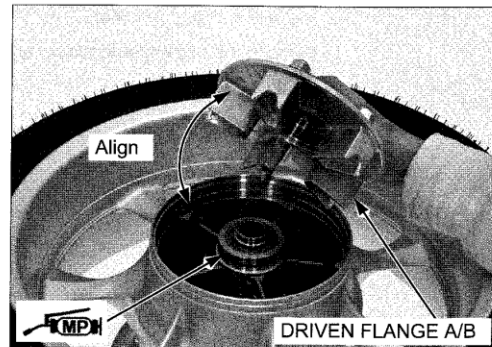

*Install the stopper ring with the chamfered edges facing the thrust load side. Make sure the stopper ring is seated in the groove.*

Install the stopper ring into the ring groove.

If the driven flange A is removed, tighten the driven flange nuts to the specified torque if they were removed.

**TORQUE: 88 N·m (9.0 kgf·m, 65 lbf·ft)**

Apply molybdenum disulfide paste to the O-ring groove of the driven flange.

Install a new O-ring.

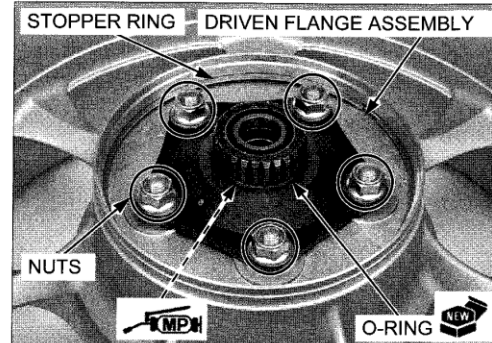

## REAR WHEEL/SUSPENSION

*Do not get grease on the brake disc or stopping power will be reduced.*

Install the brake disc with the marked side facing out. Install and tighten new disc socket bolts to the specified torque in a crisscross pattern in several steps.

**TORQUE: 42 N·m (4.3 kgf·m, 31 lbf·ft)**

Apply grease to a new dust seal lips and install it until it is flush with the wheel hub.

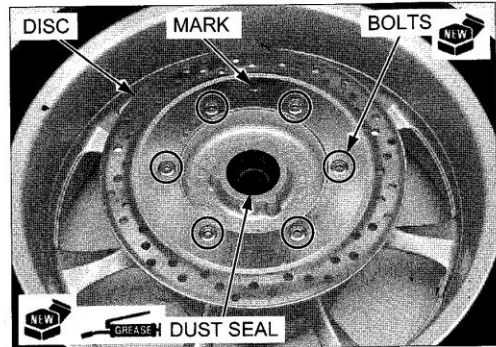

**VT1300CXA:** Install the pulser ring, pulser ring cover and new torx bolts and tighten them to the specified torque.

**TORQUE: 7 N·m (0.7 kgf·m, 5.2 lbf·ft)**

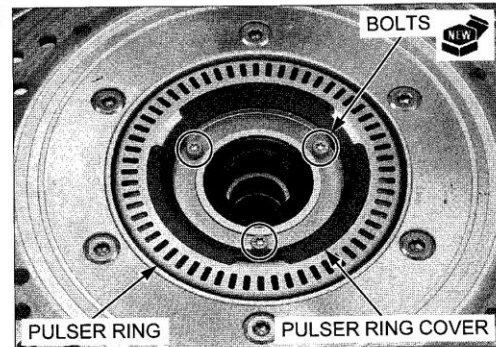

## INSTALLATION

Install the collar.

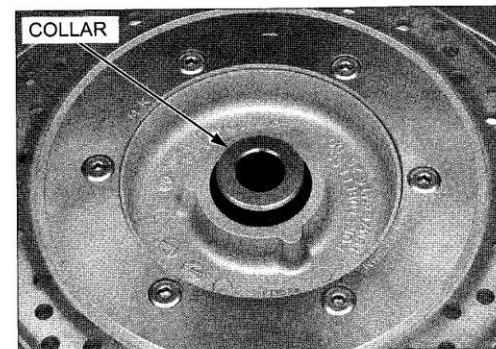

Apply 5 g (0.18 oz) minimum of molybdenum disulfide paste to the driven flange splines and O-ring.

*Hold the wheel securely and be careful not to damage the brake disc and gear case.*

Place the rear wheel into the swingarm and engage it with the gear case, making sure the splines are correctly aligned.

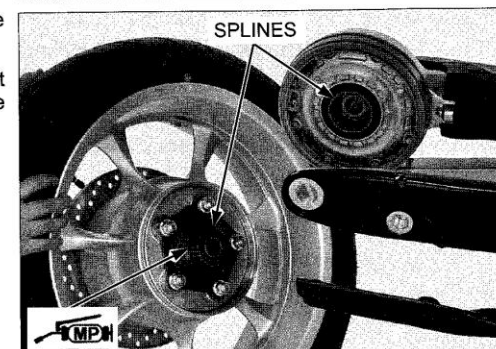

## REAR WHEEL/SUSPENSION

Apply thin coat of grease to the axle sliding surface.  
Install the axle from the left side on the way.

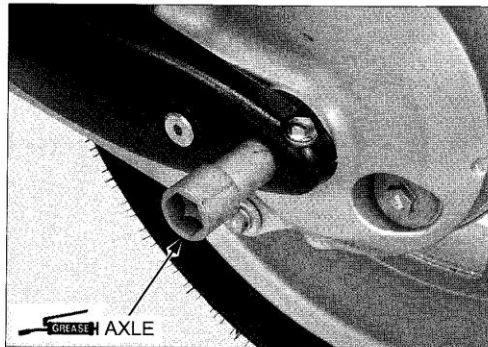

*Be careful not to damage the pads.* Install the brake caliper/bracket so the brake disc is positioned between the brake pads.

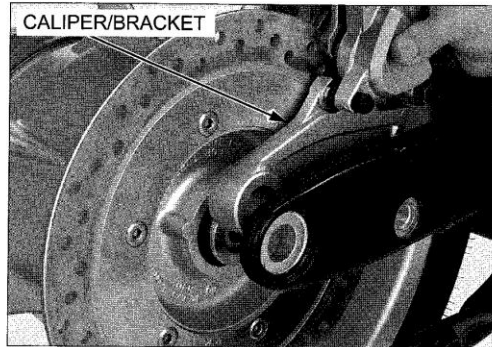

Insert the axle through the gear case, wheel, bracket and swingarm.

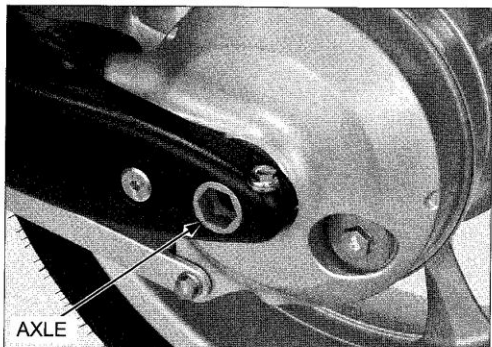

Install the washer and rear axle nut and tighten it to the specified torque.

**TORQUE: 127 N·m (13.0 kgf·m, 94 lbf·ft)**

Install and tighten a new rear brake caliper stopper pin bolt to the specified torque.

**TORQUE: 69 N·m (7.0 kgf·m, 51 lbf·ft)**

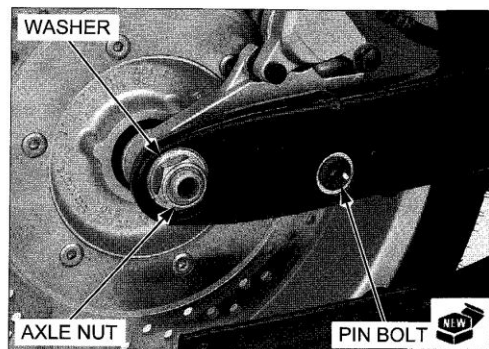

## REAR WHEEL/SUSPENSION

Tighten the rear axle pinch bolt to the specified torque.

**TORQUE: 27 N·m (2.8 kgf·m, 20 lbf·ft)**

Install the exhaust system (page 3-17).

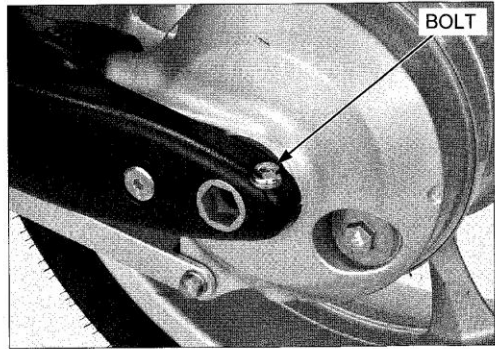

**VT1300CXA:** Install the wire clamps and tighten the bolts securely.

Install the rear wheel speed sensor and tighten the bolts securely.

Check the air gap between the rear wheel speed sensor and pulser ring (page 18-28).

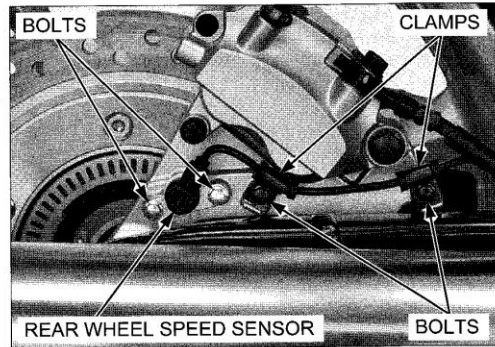

## SHOCK ABSORBER

### REMOVAL

Remove the following:

- Fuel tank (page 6-43)
- Rear fender (page 3-8)
- Rear wheel (page 16-6)

Remove the bolts and pre-load adjuster.

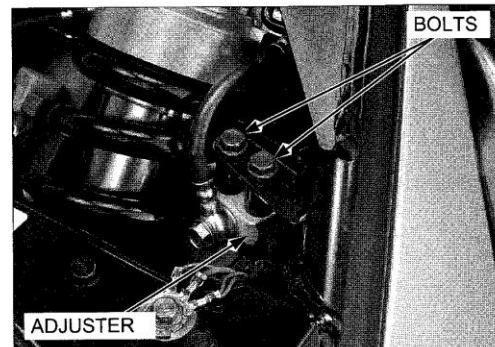

Remove the shock absorber lower mounting nut and bolt.

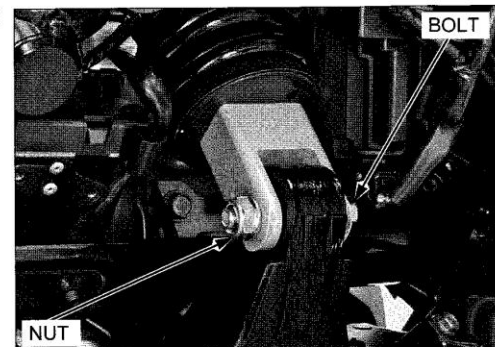

## REAR WHEEL/SUSPENSION

Remove the shock absorber upper holder nut and shock absorber.

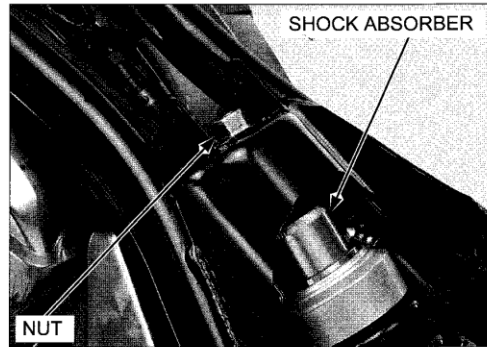

*When removing the upper holder and upper mounting bolt, mark the installing position to ensure correct reassembly in their original location.*

Remove the shock absorber upper mounting nut, bolt and upper holder.

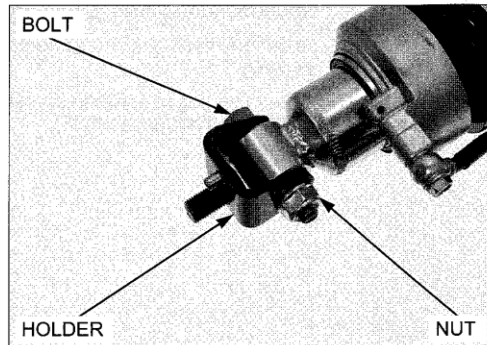

### INSPECTION

Check for deformation or oil leakage.  
Check the bushing for wear or damage.

**NOTE:**

- Replace the shock absorber as an assembly.

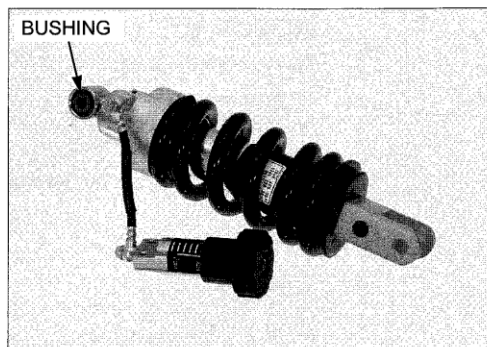

### INSTALLATION

Install the upper holder and upper mounting bolt to their original location as noted during removal.

Install and tighten the upper mounting nut to the specified torque.

**TORQUE: 44 N·m (4.5 kgf·m, 32 lbf·ft)**

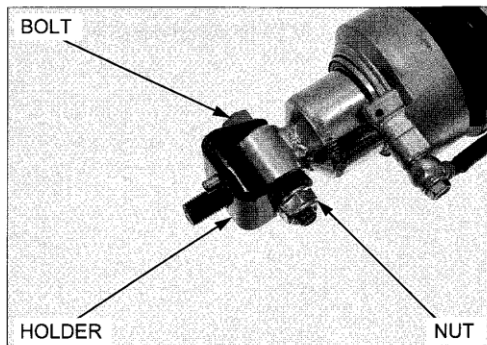



## REAR WHEEL/SUSPENSION

Install the shock absorber by aligning the boss of the upper holder with the hole of the frame.

Install and tighten the upper holder nut to the specified torque.

**TORQUE: 64 N·m (6.5 kgf-m, 47 lbf-ft)**

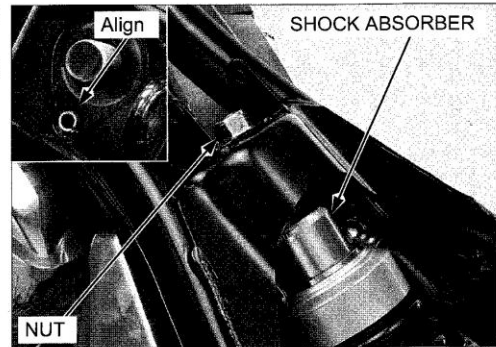

Set the shock absorber lower mount to the swingarm, then install the lower mounting bolt and nut.

Tighten the lower mounting nut to the specified torque.

**TORQUE: 44 N·m (4.5 kgf-m, 32 lbf-ft)**

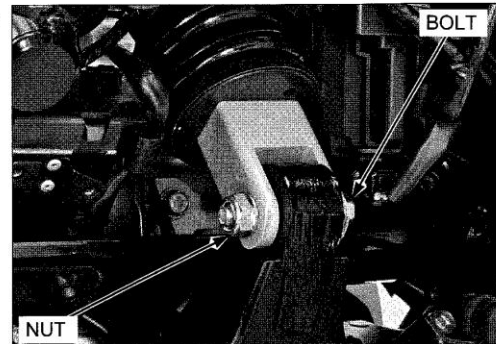

Install the pre-load adjuster and bolts. Tighten the bolts securely.

Install the following:

- Rear wheel (page 16-13)
- Rear fender (page 3-8)
- Fuel tank (page 6-43)

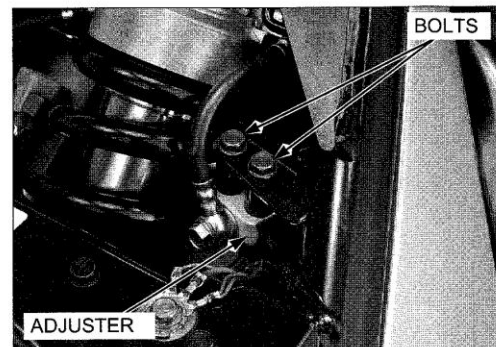

## SWINGARM

### REMOVAL

Remove the following:

- Left crankcase rear cover (page 3-7)
- Final drive (page 14-7)

Remove the left crankcase rear cover stay bolts to get the clearance for universal joint removal.

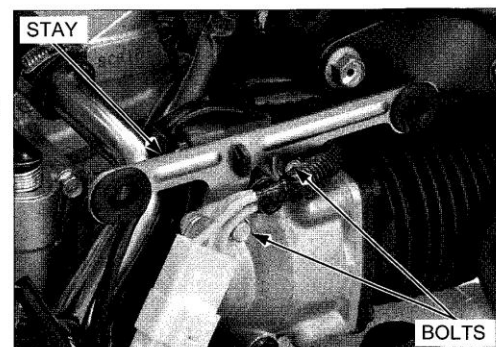

## REAR WHEEL/SUSPENSION

Release the joint boot from the output gear case and remove the universal joint from the output shaft.  
Remove the joint boot.

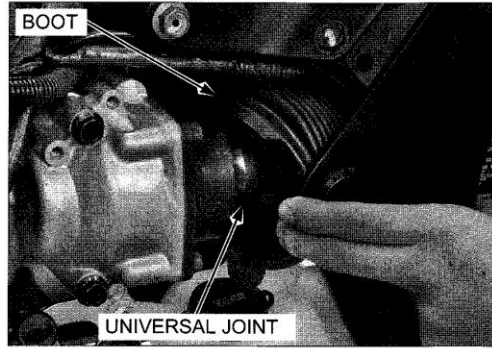

Remove the universal joint.

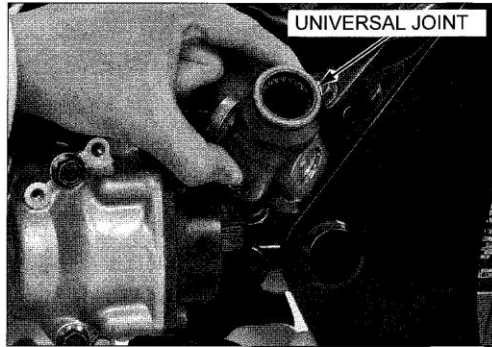

Remove the bolt and hose clamp.

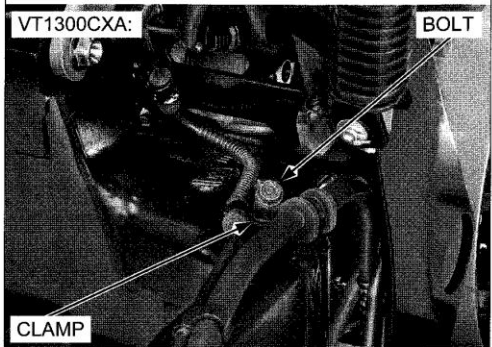
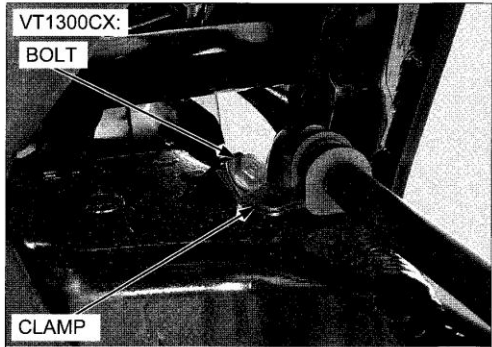

Remove the shock absorber lower mounting nut and bolt.

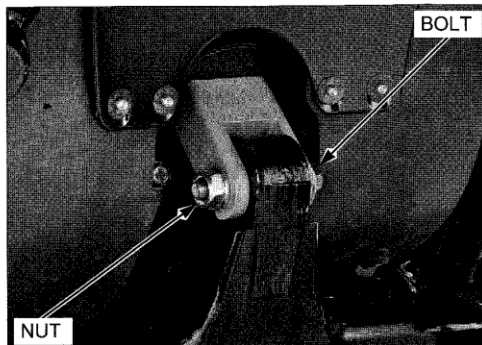

Remove the pivot cap.

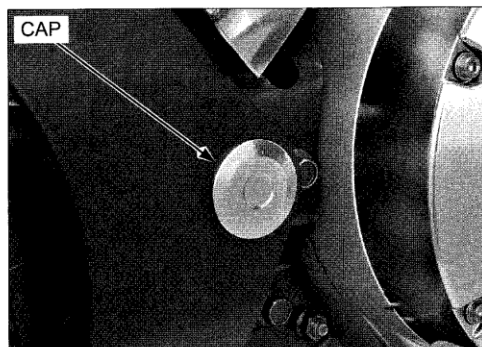

Remove the following:

- Pivot nut
- Washer
- Pivot bolt
- Swingarm

**NOTE:**

- Be careful not to damage the ABS modulator when removing the swingarm (VT1300CXA).

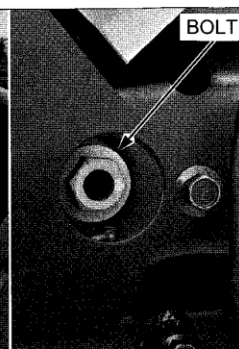
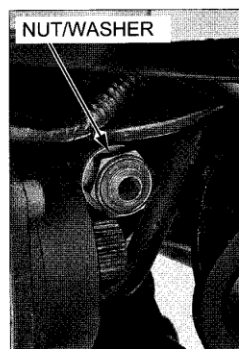

**INSPECTION**

Check the joint boot for cuts or other damage.

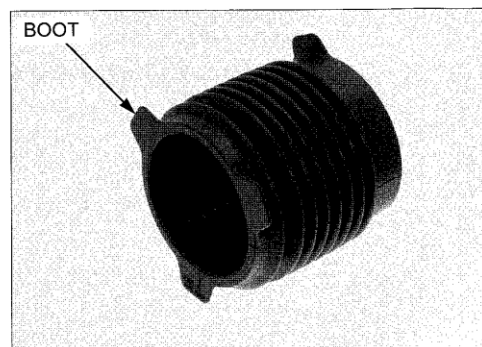

## REAR WHEEL/SUSPENSION

Check that the universal joint moves smoothly without binding or noise.  
Check the splines for wear or damage.  
If damaged, check the splines of the output driven gear shaft and drive shaft also.

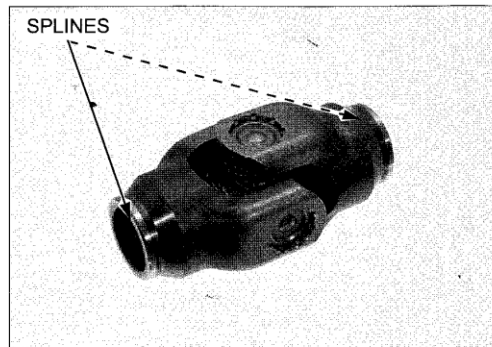

### DISASSEMBLY

Remove the nut, bolt and torque arm.  
Remove the torque arm bushing.

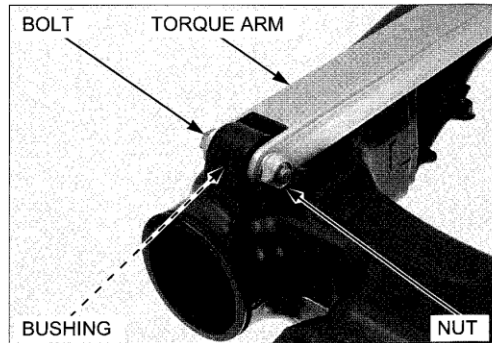

Remove the dust seals from the shock absorber lower mount of the swingarm.

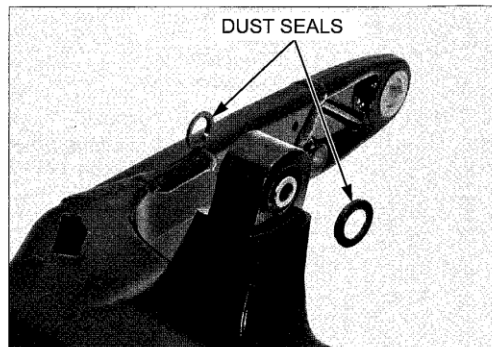

Remove the pivot collars, dust seals and distance collar from the swingarm pivot.  
Check the pivot collars for wear or damage.

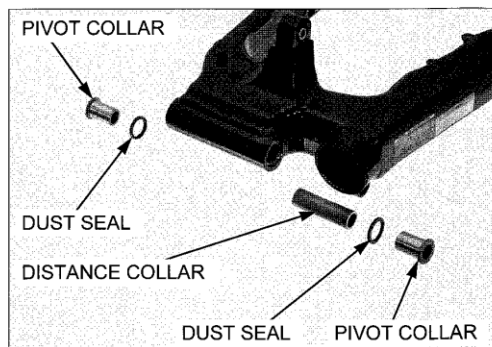

Turn the inner race of right side pivot ball bearing with your finger.  
The bearing should turn smoothly and quietly.  
Also check that the outer race fits tightly in the swingarm pivot.

Remove and discard the bearing if the races do not turn smoothly and quietly, or if the outer race fits loosely in the swingarm pivot.

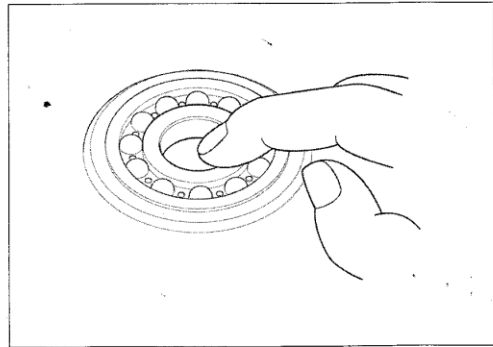

**PIVOT BEARING REPLACEMENT**

*Right side:* Remove the snap ring from the swingarm right side pivot.

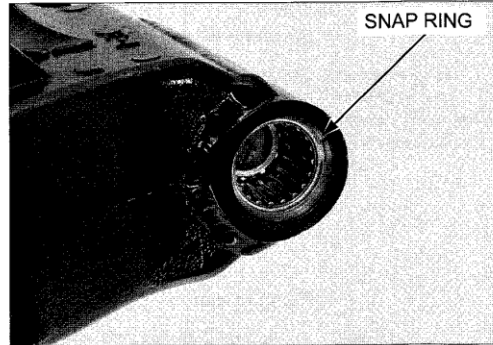

*Right side:* Press the right pivot needle and ball bearings out of the swingarm pivot using the special tools.

**TOOLS:**  
Driver 07949-3710001  
Attachment, 24 x 26 mm 07746-0010700  
Pilot, 20 mm 07746-0040500

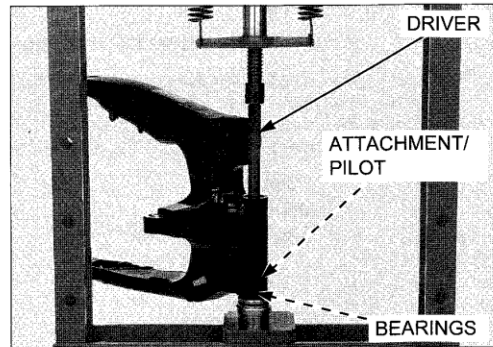

*Left side:* Press the left pivot needle bearing out of the swingarm pivot using the special tools.

**TOOLS:**  
Driver 07949-3710001  
Pilot, 32 mm 07MAD-PR90200

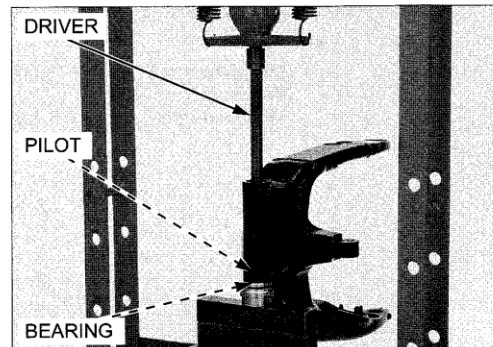

## REAR WHEEL/SUSPENSION

*Right side:* Place a new ball bearing onto the swingarm right pivot.

*Press the ball bearing into the swingarm with the marked side facing out.* Support the swingarm horizontally and press the ball bearing until it is fully seated using the special tools.

**TOOLS:**

**Driver**  
**Attachment, 37 mm**

**07749-0010000**  
**07ZMD-MBW0200**  
**or**  
**07ZMD-MBWA200**  
**(U.S.A. only)**  
**07746-0040500**

**Pilot, 20 mm**

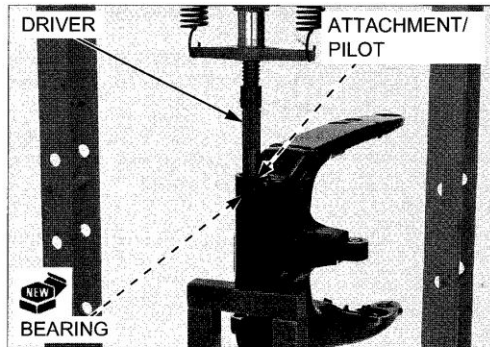

*Right side:* Apply molybdenum disulfide grease to a new needle bearing.

Place the needle bearing on to the swingarm right pivot.

*Press the needle bearing into the swingarm with the marked side facing out.* Support the swingarm horizontally and press the needle bearing until it is fully seated on ball bearing using the special tools.

**TOOLS:**

**Driver**  
**Attachment, 37 mm**

**07749-0010000**  
**07ZMD-MBW0200**  
**or**  
**07ZMD-MBWA200**  
**(U.S.A. only)**  
**07746-0041100**

**Pilot, 28 mm**

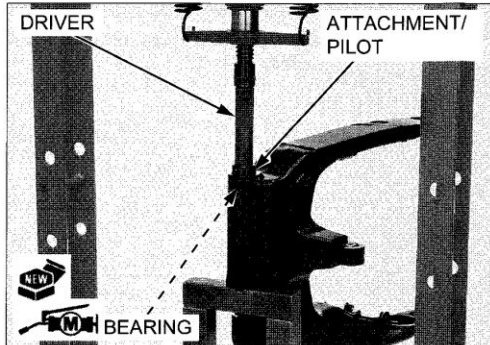

*Left side:* Apply molybdenum disulfide grease to a new needle bearing.

Place the needle onto the swingarm left pivot.

*Press the needle bearing into the swingarm with the marked side facing out.* Support the swingarm horizontally and press the needle bearing so that the needle bearing surface is 4.5 – 5.5 mm (0.18 – 0.22 in) below the end of the swingarm pivot surface using the special tools.

**TOOLS:**

**Driver**  
**Attachment, 37 mm**

**07749-0010000**  
**07ZMD-MBW0200**  
**or**  
**07ZMD-MBWA200**  
**(U.S.A. only)**  
**07746-0041100**

**Pilot, 28 mm**

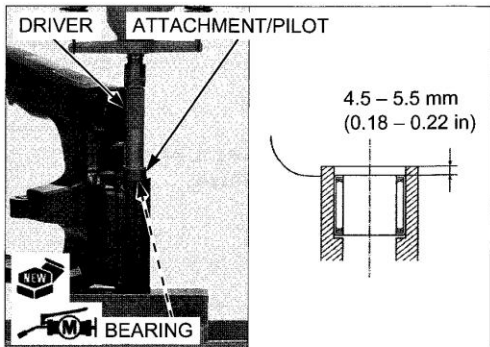

*Right side:* Install the snap ring into the groove.

**NOTE:**

- Install the snap ring with the chamfered edges facing the thrust load side.
- Make sure the snap ring is seated in the groove.

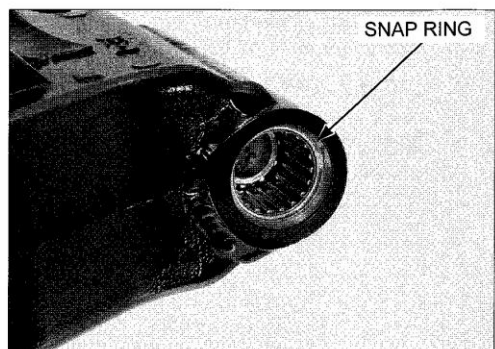

**SHOCK ABSORBER LOWER MOUNT BEARING REPLACEMENT**

Press the spherical bearing out of the swingarm using the special tools.

**TOOLS:**  
Installer, 15/23

07GMD-KT80100  
("Collar, 23 x 17 mm"  
is only required) or  
07GMD-KT8A110  
(U.S.A. only)  
07746-0030300

Attachment, 30 mm I.D.

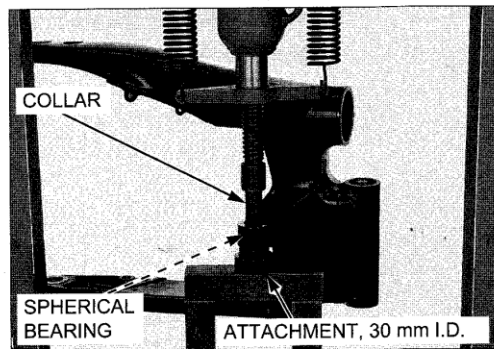

Place a new spherical bearing onto the swingarm.

Support the swingarm horizontally and press the spherical bearing into the swingarm so that the spherical bearing surface is 7.3 – 7.7 mm (0.29 – 0.30 in) below the end of the swingarm using the special tools.

**TOOLS:**  
Installer, 15/23

07GMD-KT80100  
("Collar, 23 x 17 mm"  
is only required) or  
07GMD-KT8A110  
(U.S.A. only)  
07746-0030300

Attachment, 30 mm I.D.

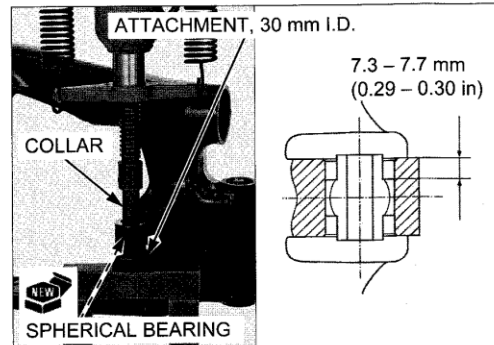

**ASSEMBLY**

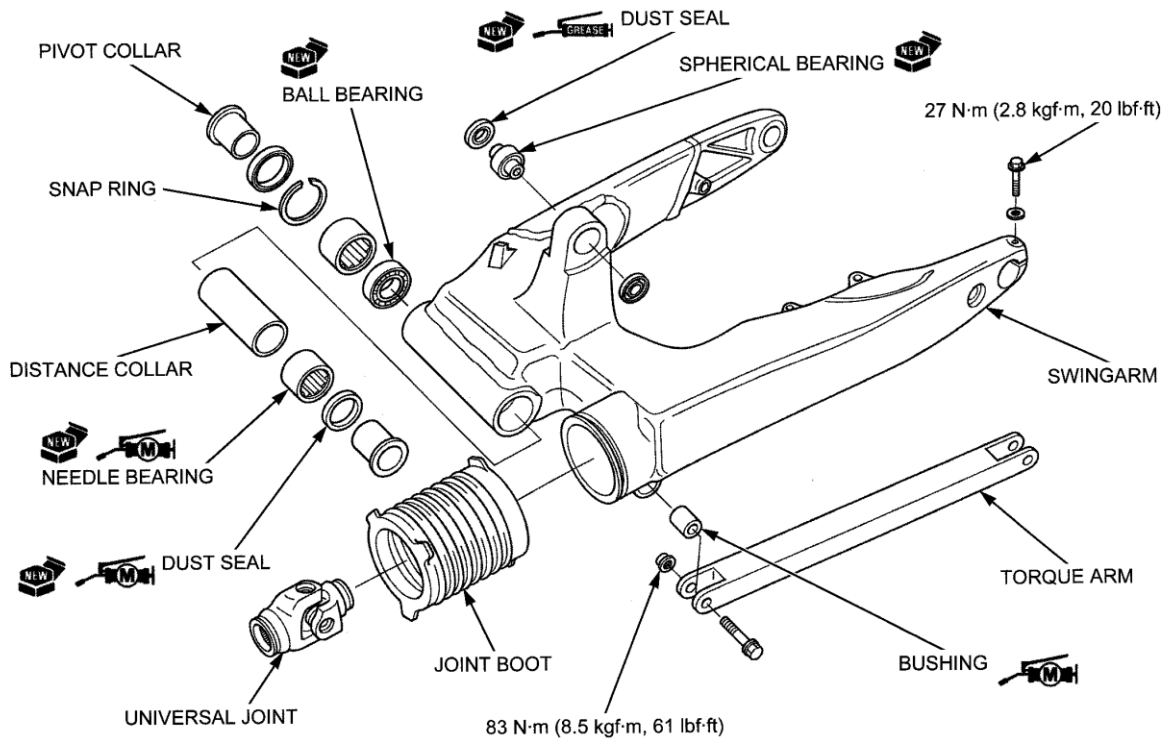

## REAR WHEEL/SUSPENSION

Install the distance collar.

Apply molybdenum disulfide grease to new swingarm pivot dust seal lips and install them.

Install the pivot collars.

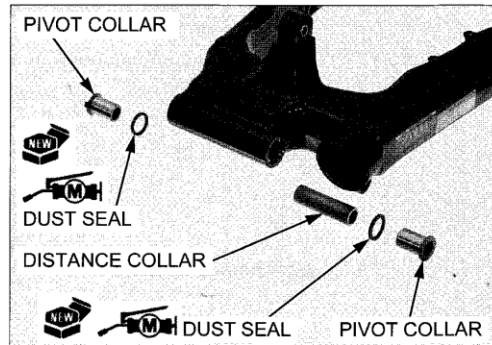

Apply grease to new shock absorber lower mount dust seal lips and install them with the flat side facing toward the bearing side.

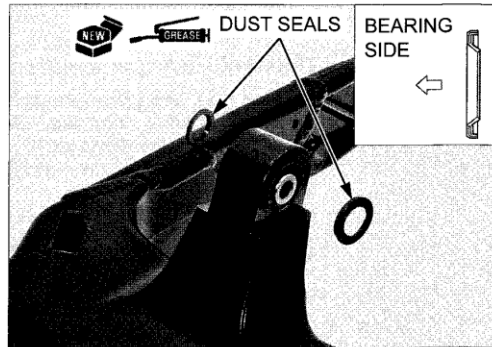

Apply molybdenum disulfide grease to the torque arm bushing outer surface and install it into the swingarm.

Install the torque arm, bolt and nut.

Tighten the nut, while holding the bolt to the specified torque.

**TORQUE: 83 N·m (8.5 kgf·m, 61 lbf·ft)**

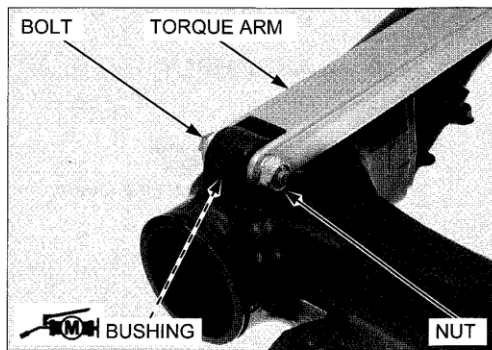

## INSTALLATION

Apply thin coat of grease to the swingarm pivot bolt sliding surface.

Install the swingarm, then install the pivot bolt from the right side.

**NOTE:**

- Be careful not to damage the ABS modulator when installing the swingarm (VT1300CXA).

Install the washer and pivot nut.

Tighten the pivot bolt to the specified torque.

**TORQUE: 142 N·m (14.5 kgf·m, 105 lbf·ft)**

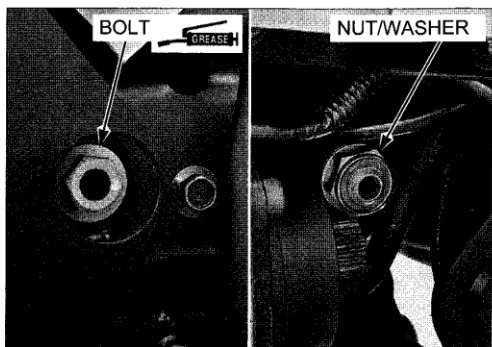



Install the pivot cap.

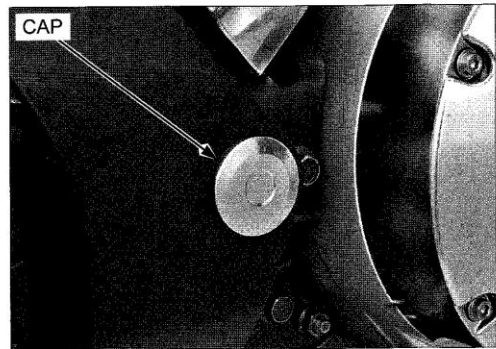

Set the shock absorber lower mount of the swingarm to the shock absorber, then install the lower mounting bolt. Install and tighten the nut to the specified torque.

**TORQUE: 44 N·m (4.5 kgf·m, 32 lbf·ft)**

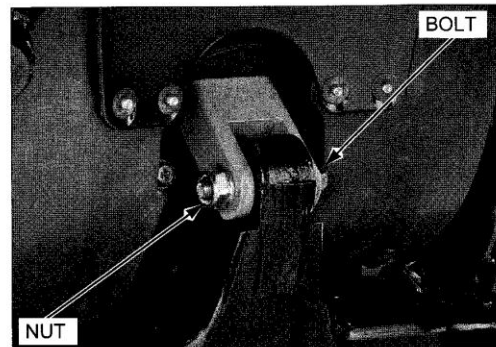

Install the hose clamp with the clamp bolt. Tighten the bolt to the specified torque.

**TORQUE: 12 N·m (1.2 kgf·m, 9 lbf·ft)**

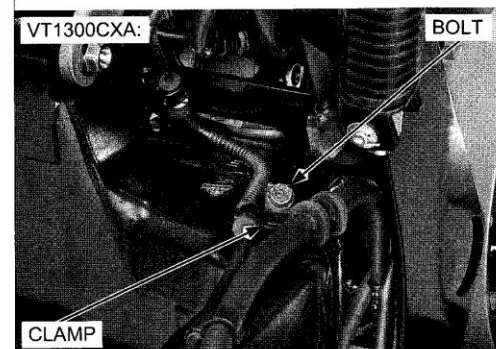
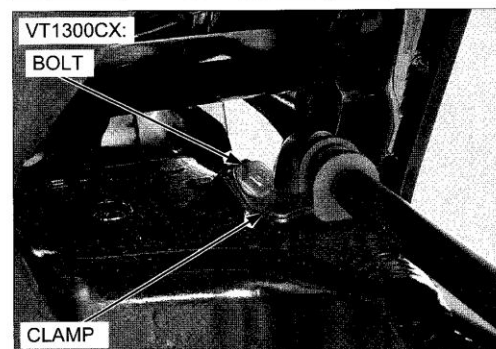

## REAR WHEEL/SUSPENSION

Apply 1 g (0.04 oz) of molybdenum disulfide grease to the output shaft splines.

Insert the universal joint into the swingarm, but not install onto the output shaft yet.

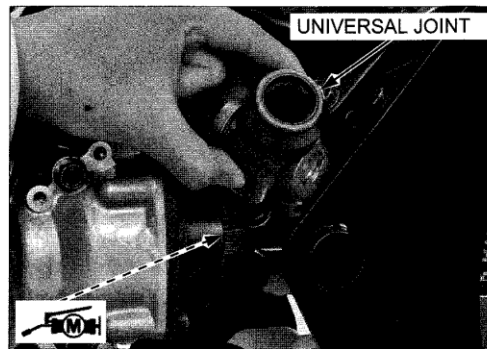

Install the joint boot to the swingarm with the "↓" mark facing down and engine side.

Install the universal joint align the output shaft splines with the universal joint splines.

Install the joint boot to the output gear case.

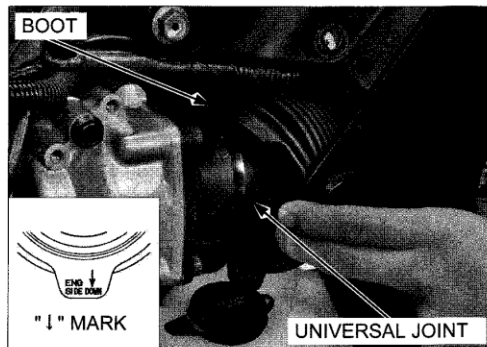

Reposition the left crankcase rear cover stay. Install and tighten the bolts.

Install the following:

- Final drive gear case (page 14-27)
- Left crankcase rear cover (page 3-7)

